

# Structuration au coeur des matériaux transparents

L. Repond; R. Villiger; F. Senn; R. Holtz

University of Applied Sciences and Arts

Northwestern Switzerland

*Institute of Product and Production Engineering IPPE*

June 04, 2015

[www.fhnw.ch/technik/ippe](http://www.fhnw.ch/technik/ippe)

# Structuration au coeur des matériaux transparents



- ▶ History
- ▶ New challenges
- ▶ Example
- ▶ Surfaces
- ▶ Applications
- ▶ Outlook
- ▶ Q & A

1960 1970 1980 1990 2000 2010 ...

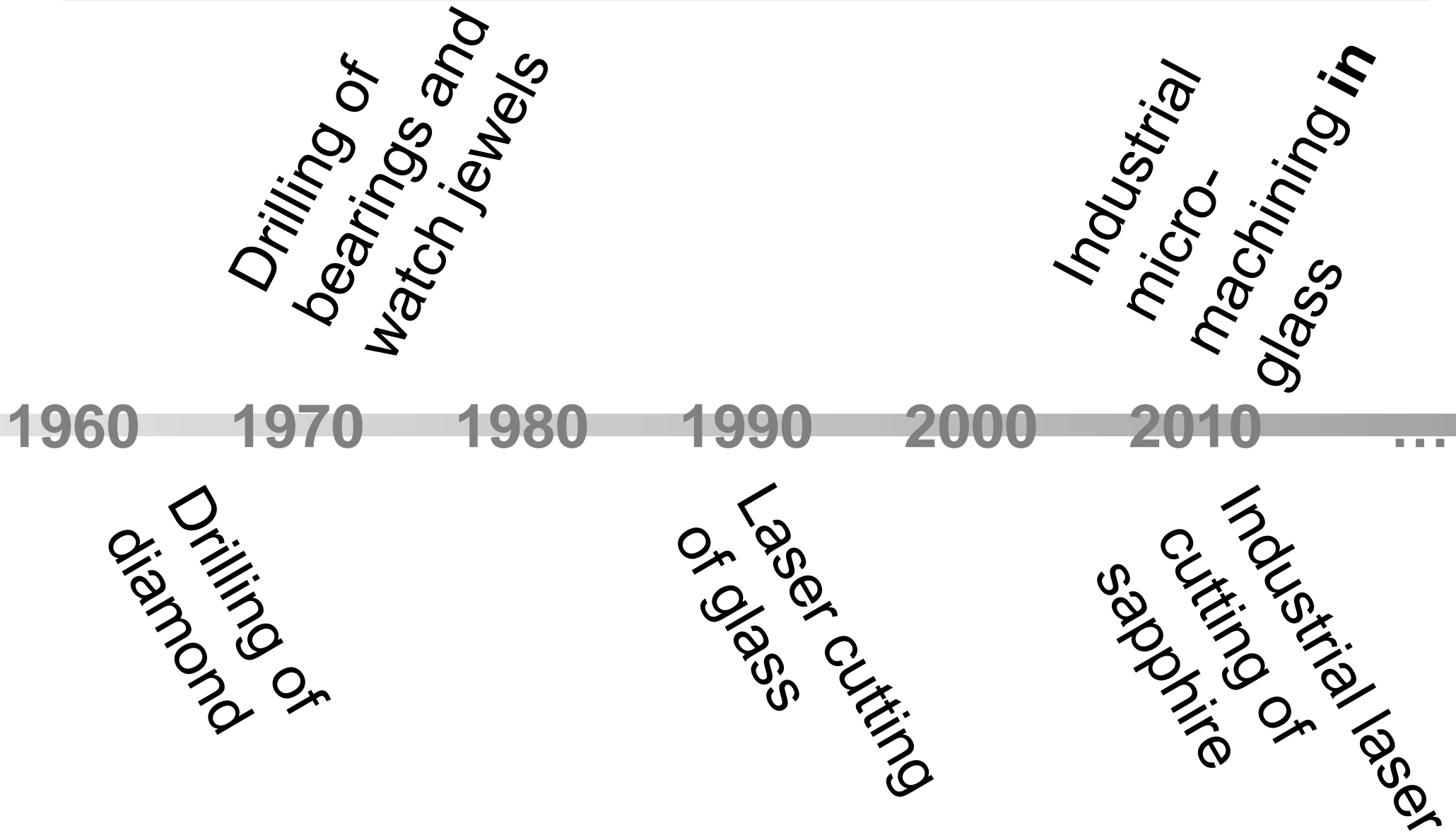

Drilling of bearings and watch jewels

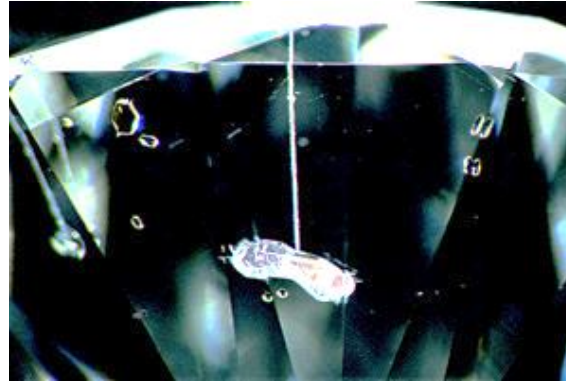

Industrial micro-machining in glass

1960 1970 1980 1990 2000 2010 ...

Drilling of diamond

Laser cutting of glass

Industrial laser cutting of sapphire

Drilling of bearings and watch jewels



Industrial micro-machining in glass

1960 1970 1980 1990 2000 2010 ...

Drilling of diamond

Laser cutting of glass

Industrial laser cutting of sapphire

Drilling of bearings and watch jewels



Industrial micro-machining in glass

1960 1970 1980 1990 2000 2010 ...

Drilling of diamond

Laser cutting of glass

Industrial laser cutting of sapphire



Drilling of bearings and watch jewels

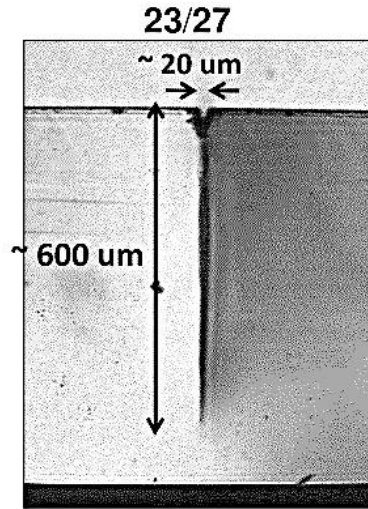

Industrial micro-machining in glass

1960 1970 1980 1990 2000 2010 ...

Drilling of diamond

Laser cutting of glass

Industrial laser cutting of sapphire

Drilling of bearings and watch jewels

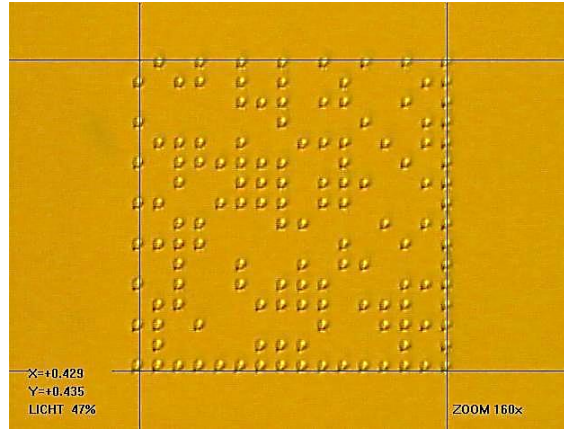

Industrial micro-machining in glass

1960 1970 1980 1990 2000 2010 ...

Drilling of diamond

Laser cutting of glass

Industrial laser cutting of sapphire

## Modify optical properties

Windows with lamellae

Optical gratings

Optical filters

## Security and traceability

Consumer electronics

Pharmaceutical  
industry

Luxury goods

Data storage

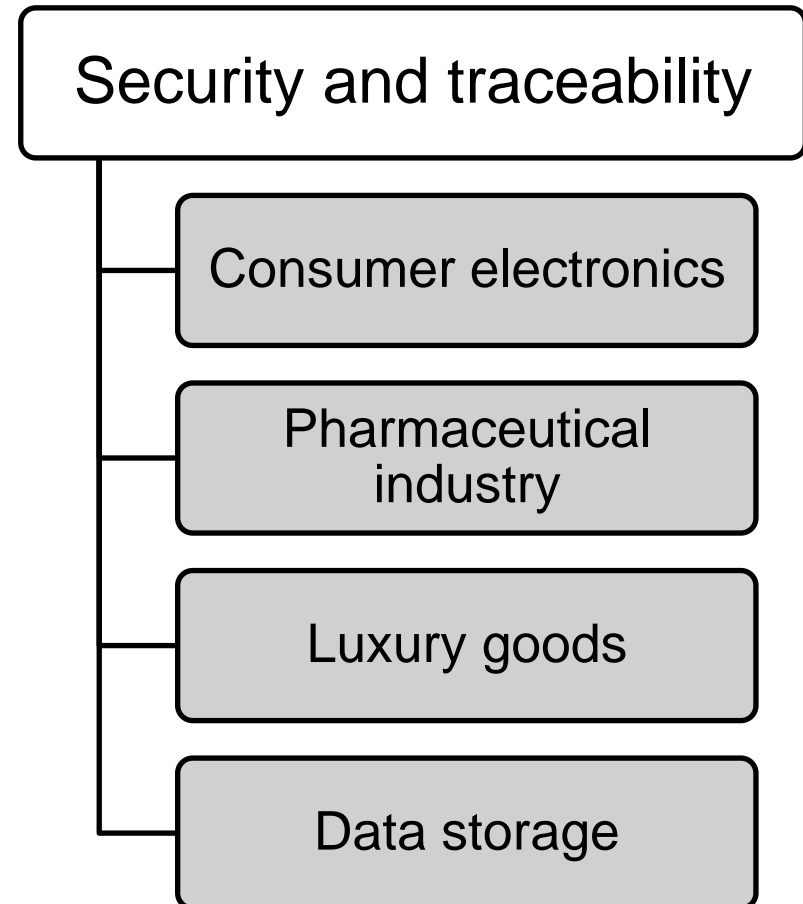
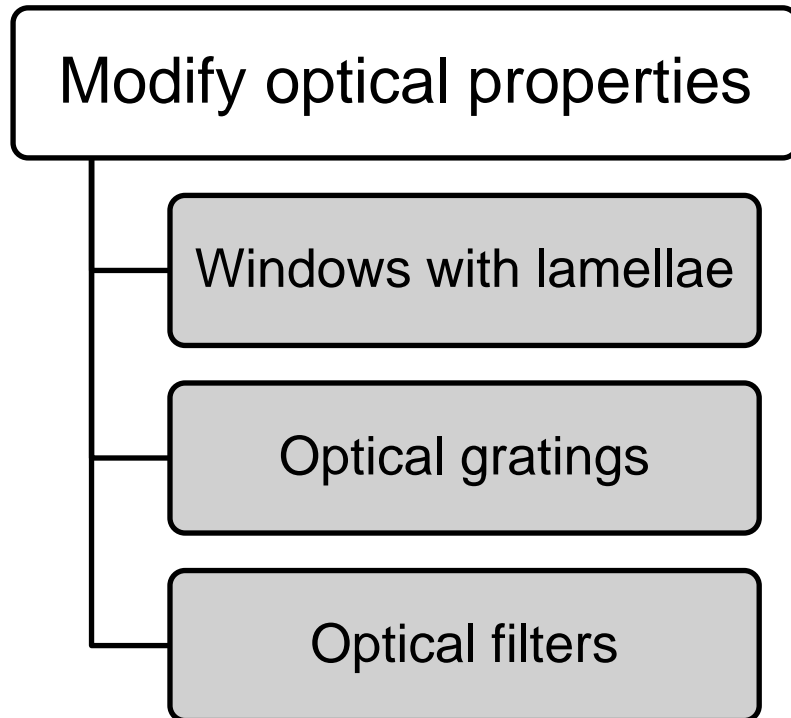

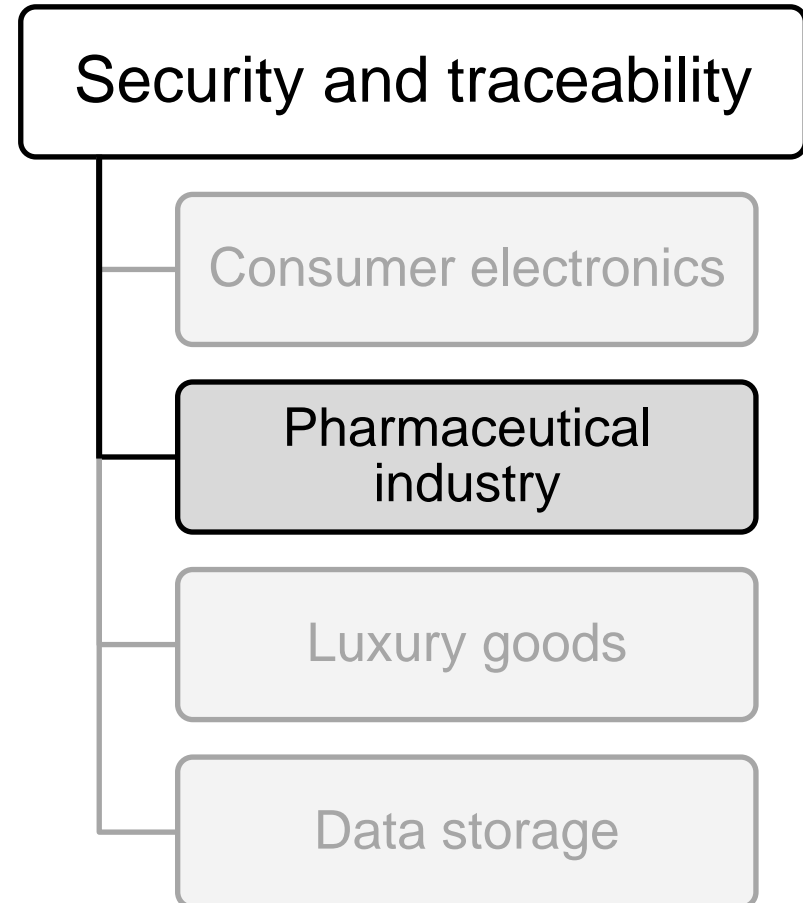
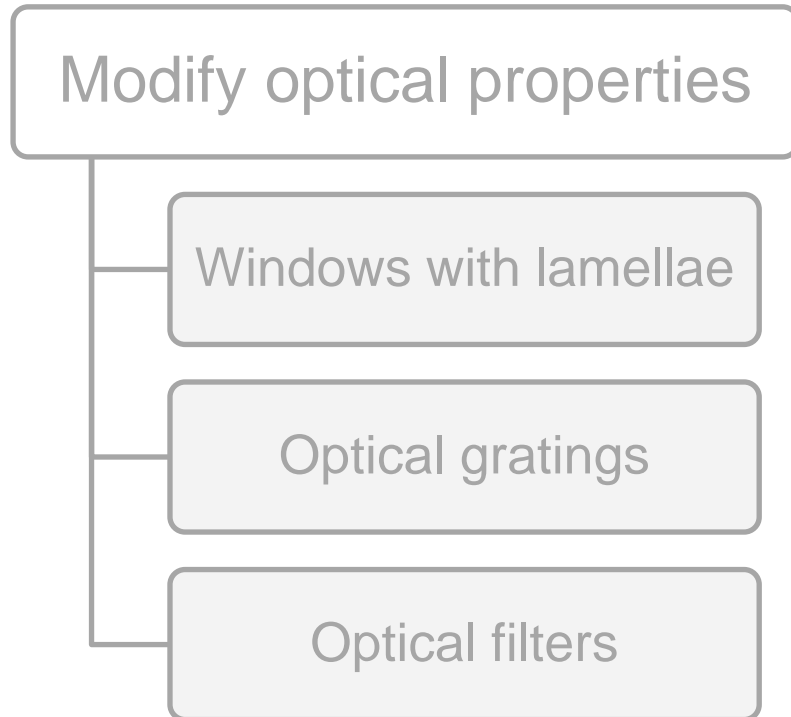

- European commission
  - «EU Fights Fake Medicines» (2011)
  - «Europe, putting patient first» (2011)
  - «Safe medicines for the EU» (2012)
- New guidelines (2011/62/EU)
- Implementation by 2018

[http://ec.europa.eu/health/human-use/falsified\\_medicines/index\\_en.htm](http://ec.europa.eu/health/human-use/falsified_medicines/index_en.htm)

## Disposable syringes 1.0 ml



### Typical applications

- EPO
- Insulin
- etc.

### Competences IPPE

- Writing security code
- Reading security code

**SCHOTT**

# Example

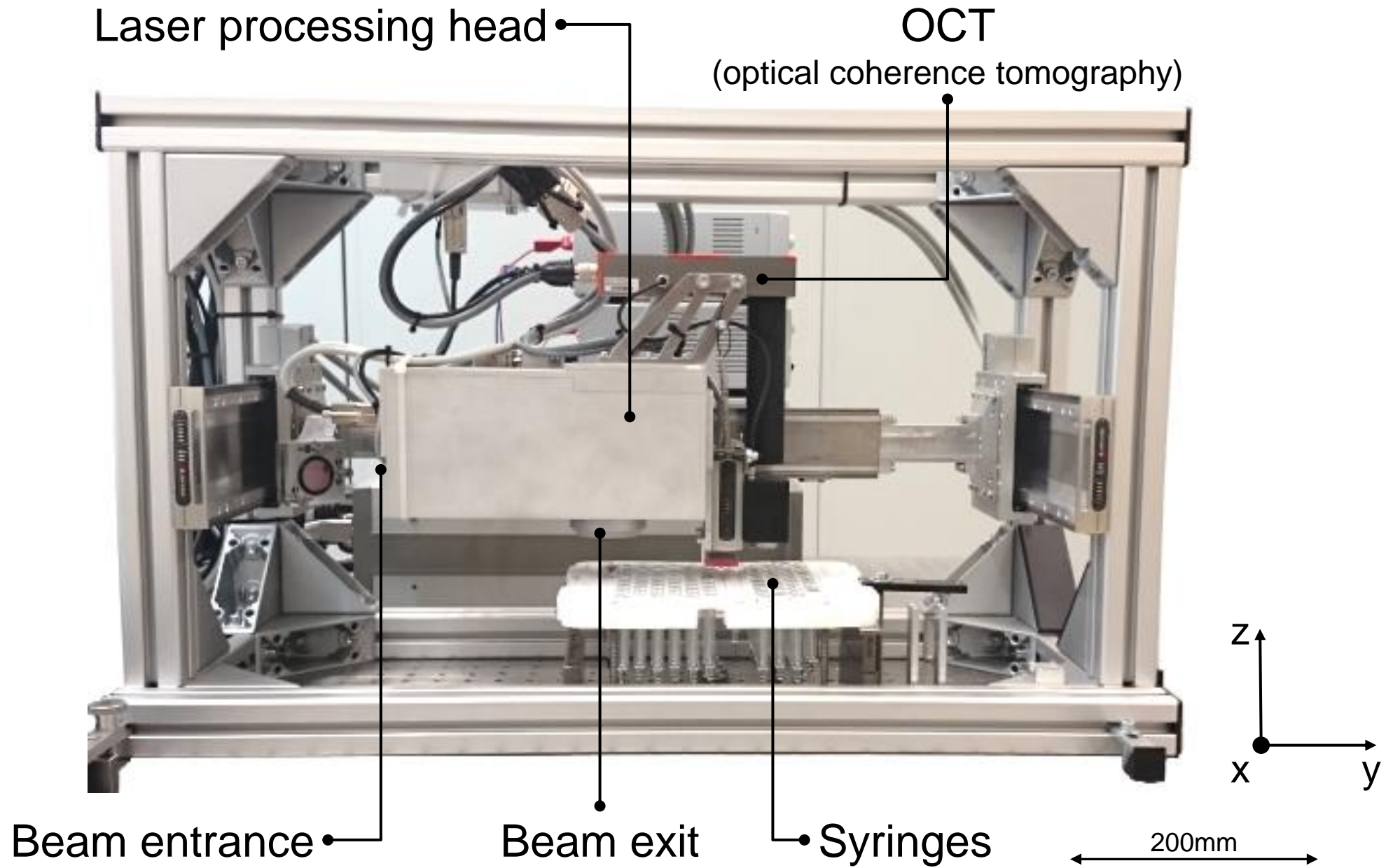



# Example

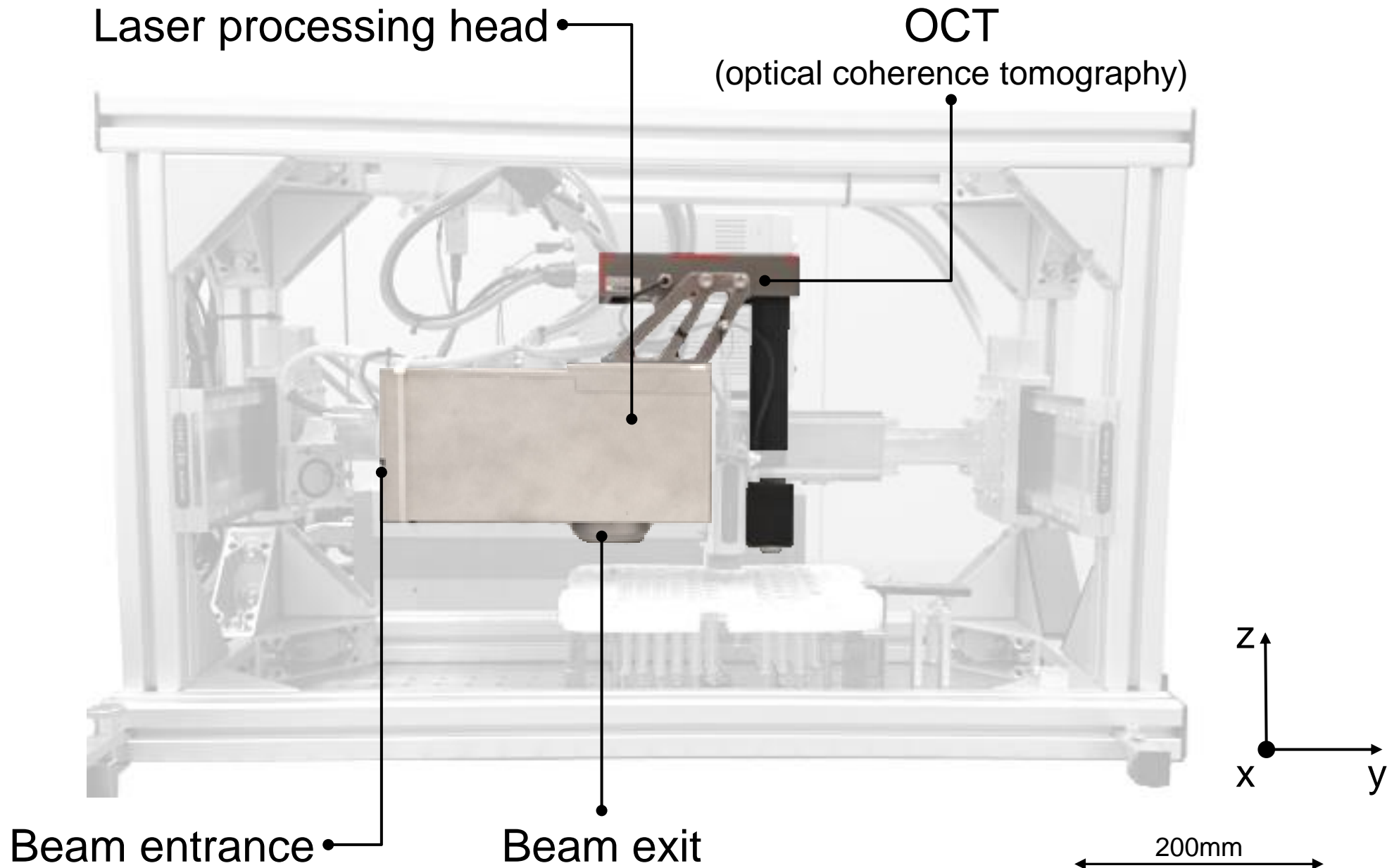

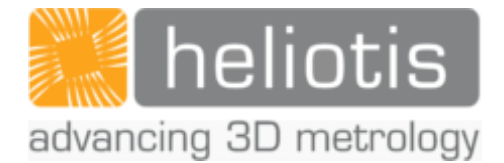
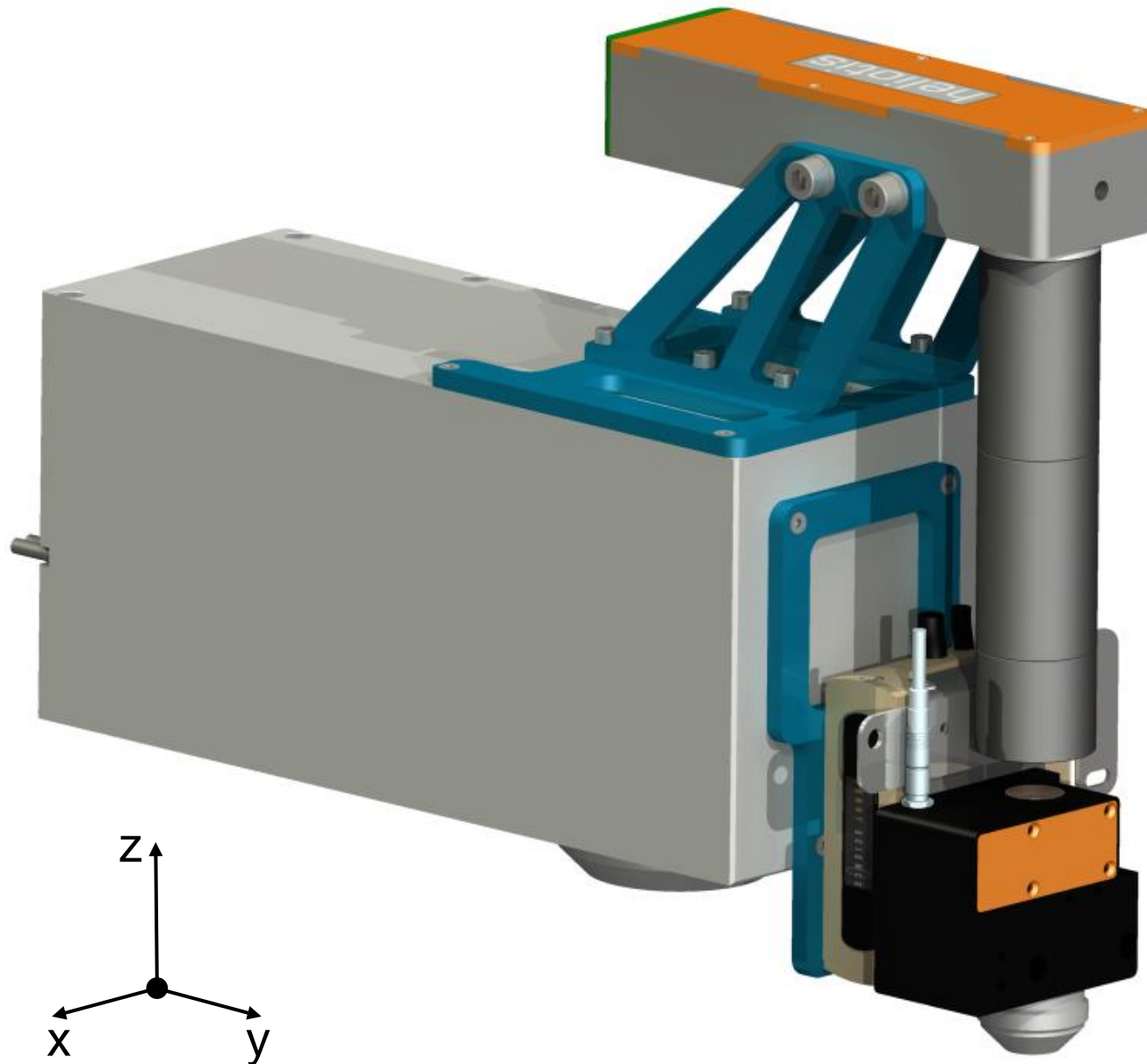

## Laser processing head

- Cleanroom compatible
- Cooling by convection
- 3kg (25% less than other systems)
- Fast accelerations and high speeds
- Minimal code size 100x100 $\mu$ m

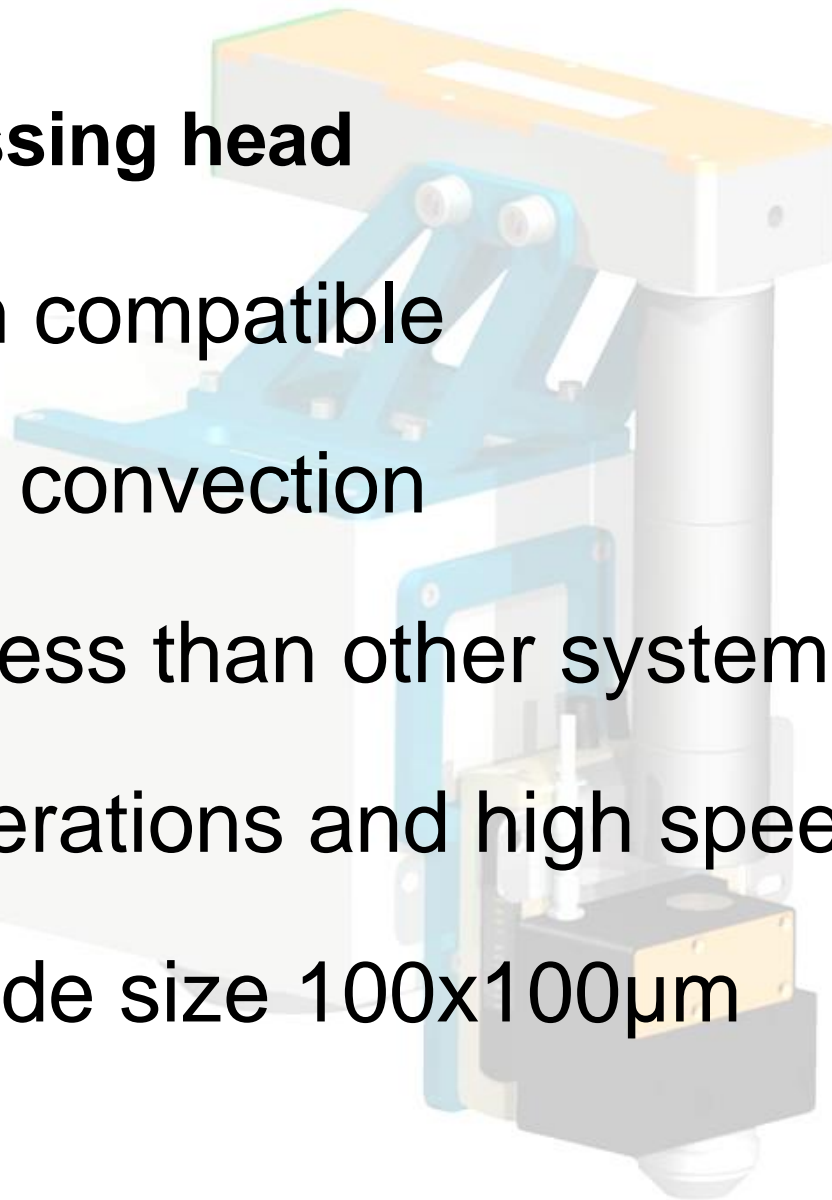

## Code-writing process

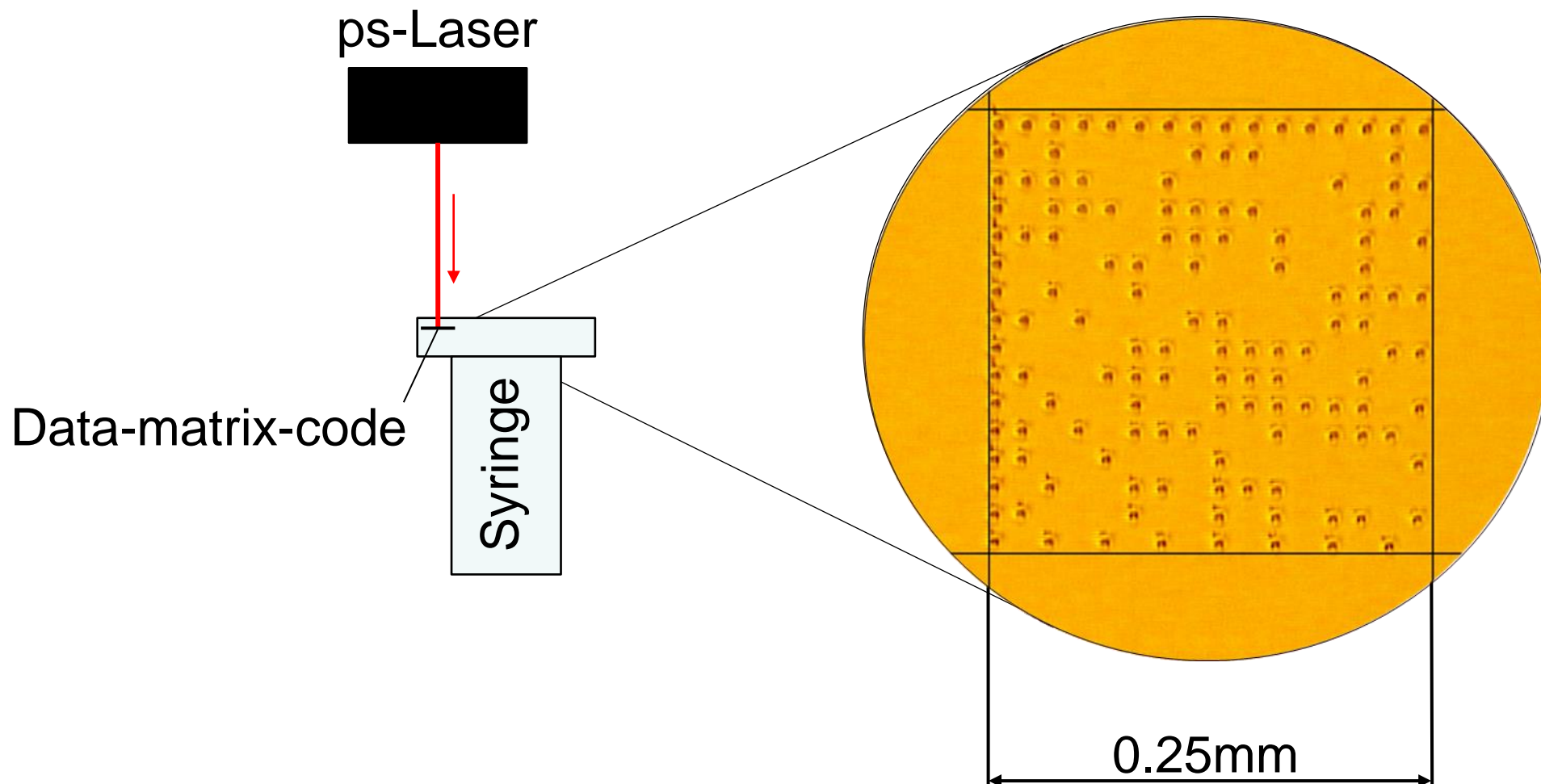

# Code-reading process

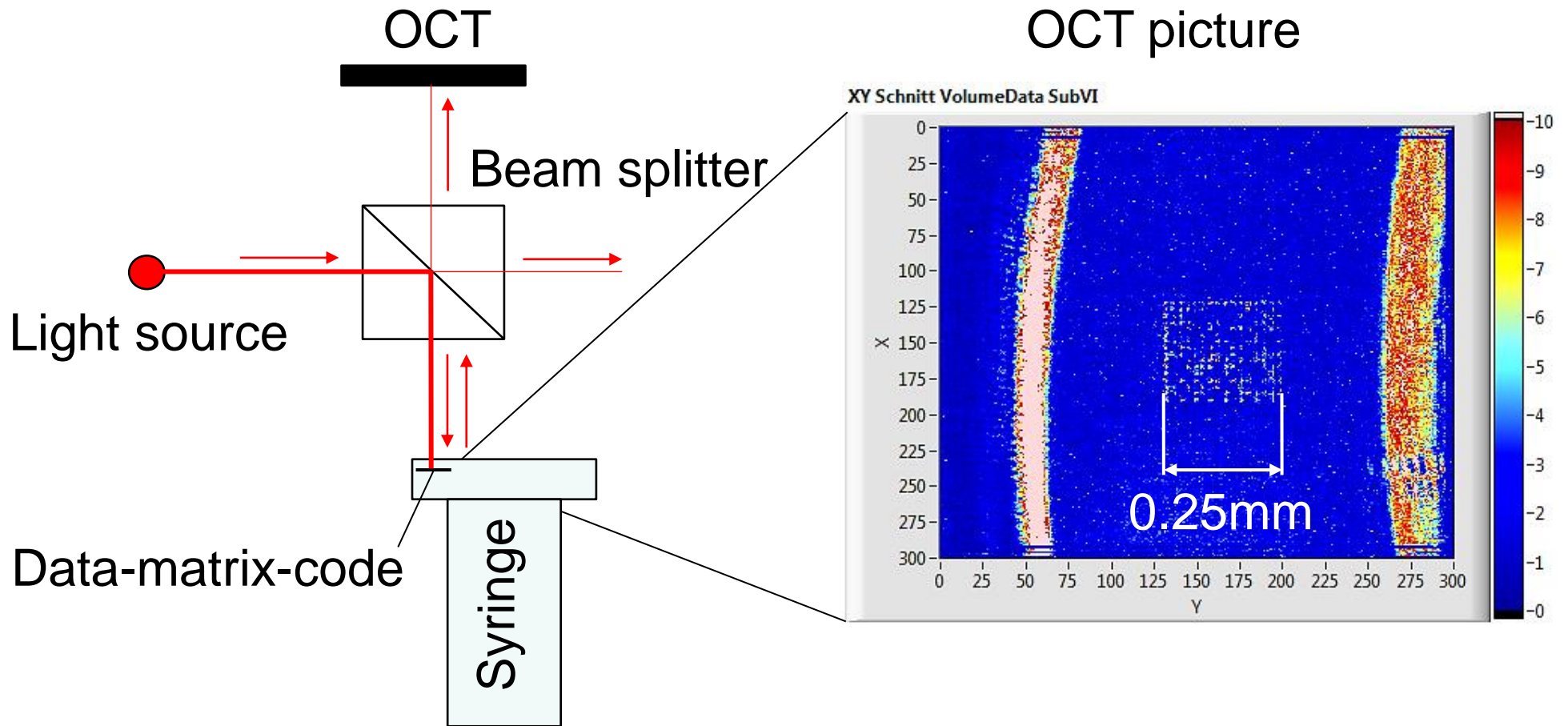

## Code-reading process

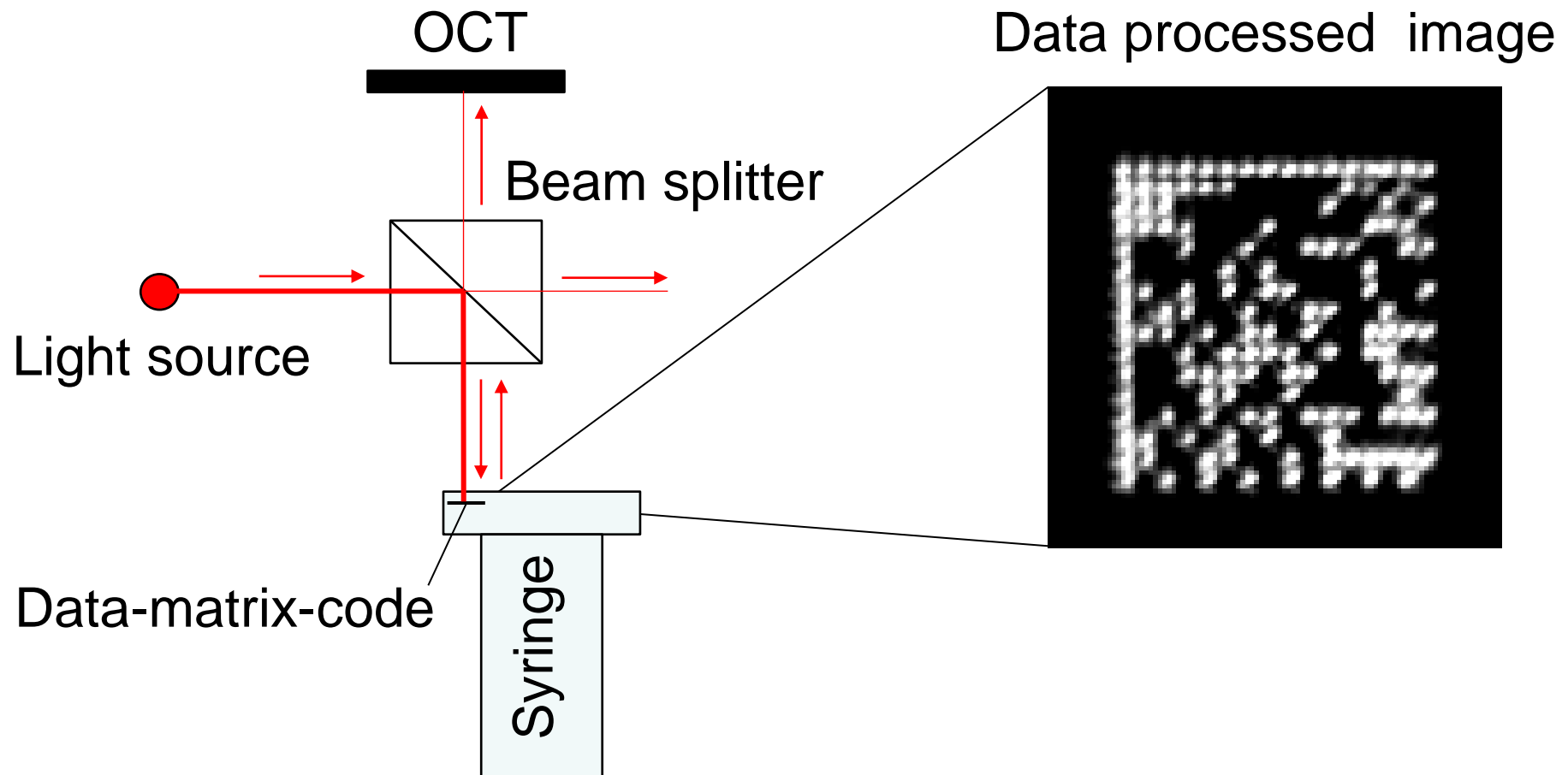

## We make dots, not cracks!

### Micro dots

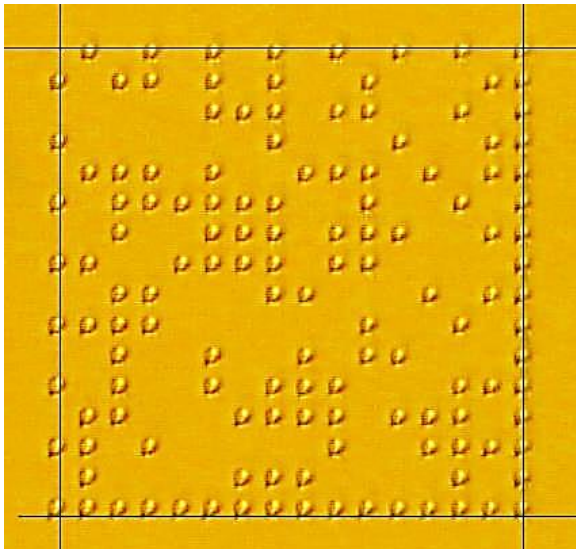

- «cold process»
- No loss of stability

### Cracks

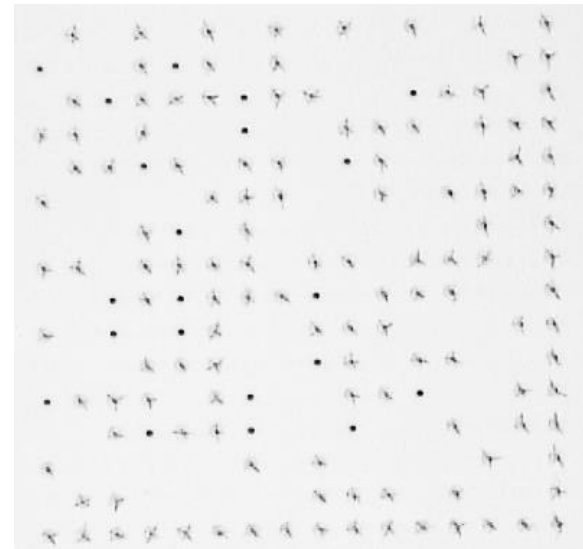

- Too much energy
- Internal tension
- Complete break under load

## Multiple layers

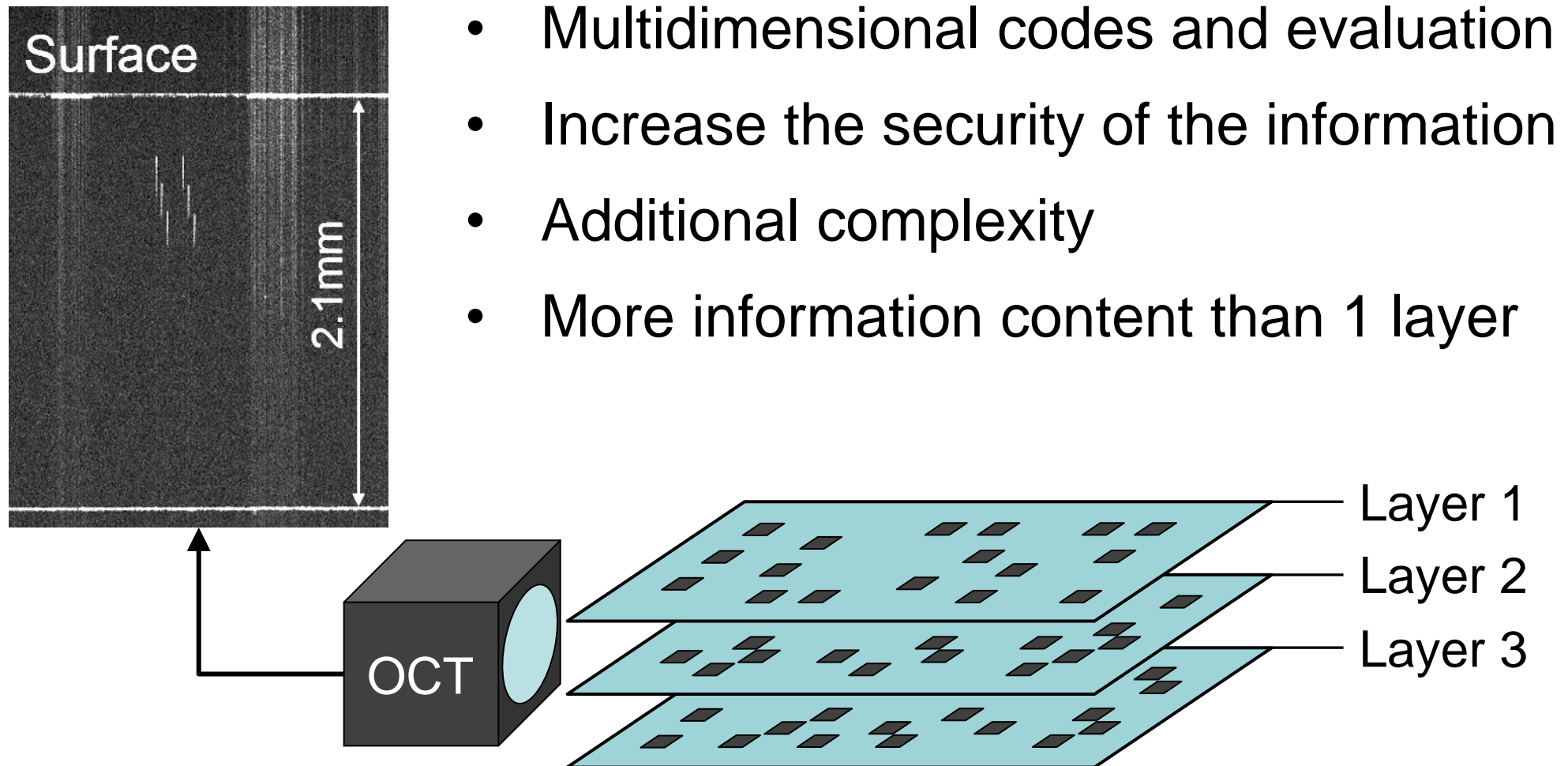



## **Challenging surfaces**

- Caused during the production

*Scratches*

*Pores, Cavities*

- Can be tackled by IPPE

*Surface geometry*

## Good surface quality

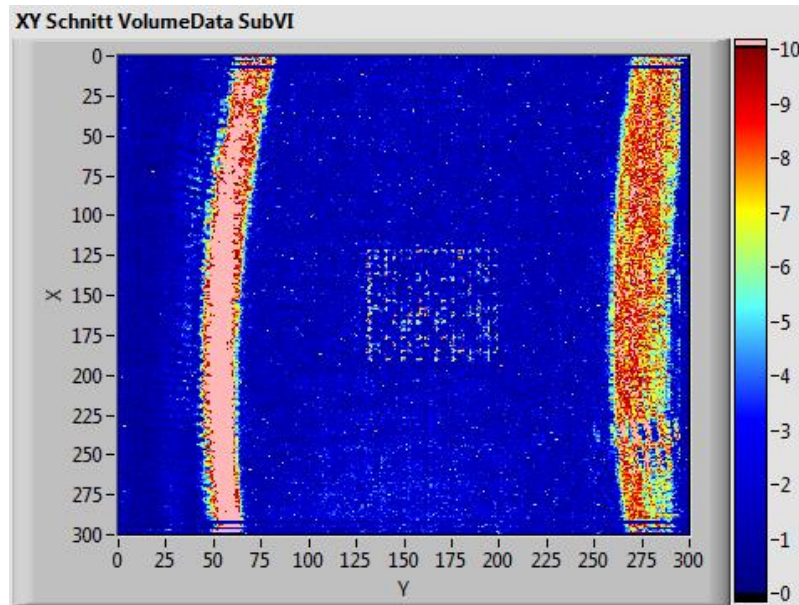

## Bad surface quality

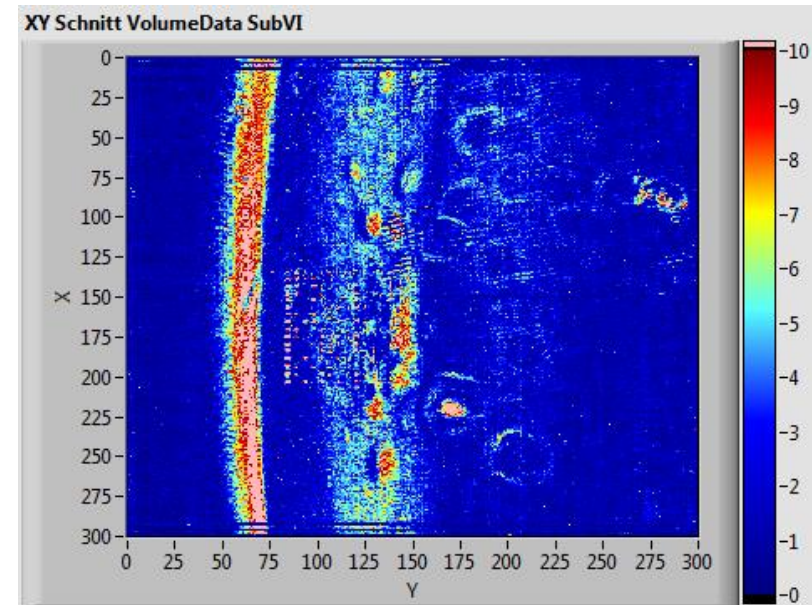

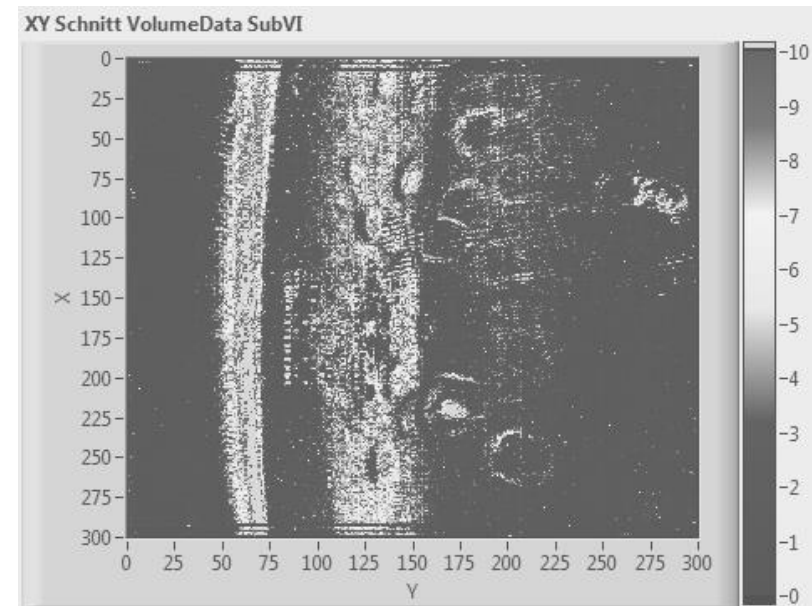
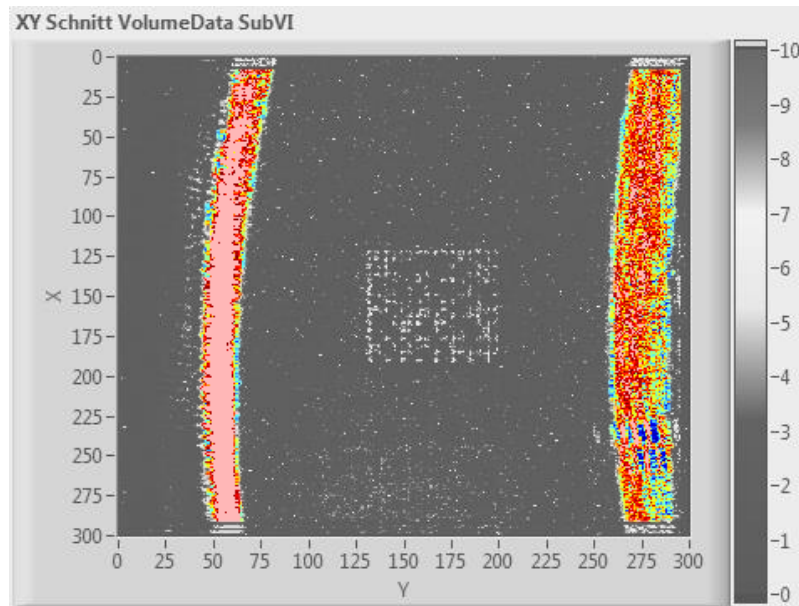

- Syringe-flange edges (red)

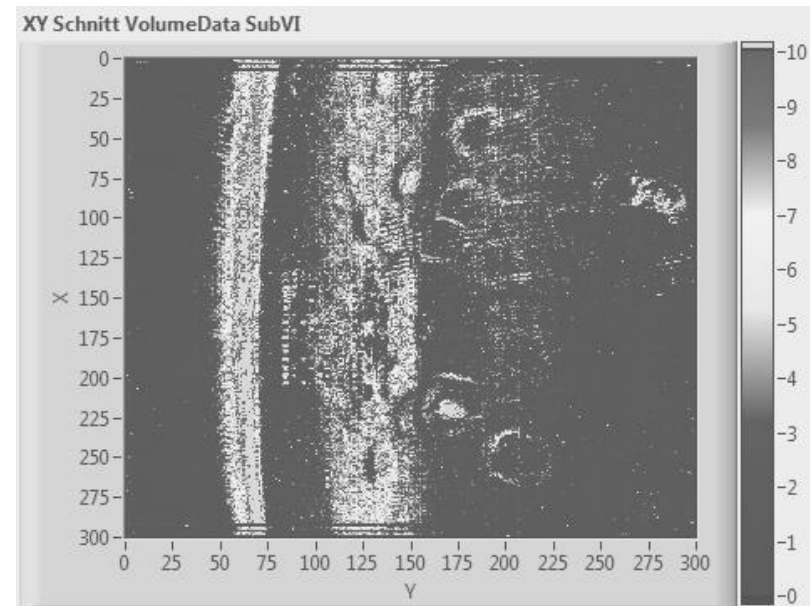
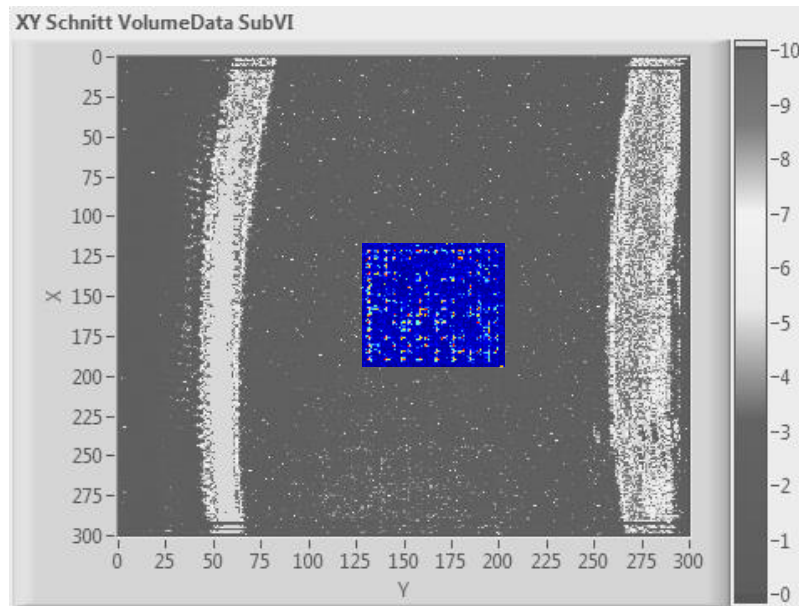

- No scratches
- No pores or cavities
- Very clear picture (blue)

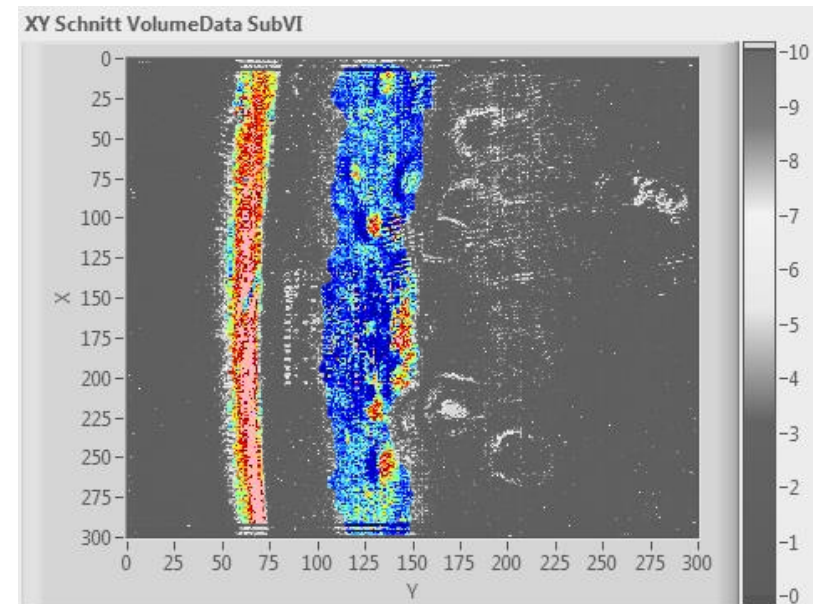
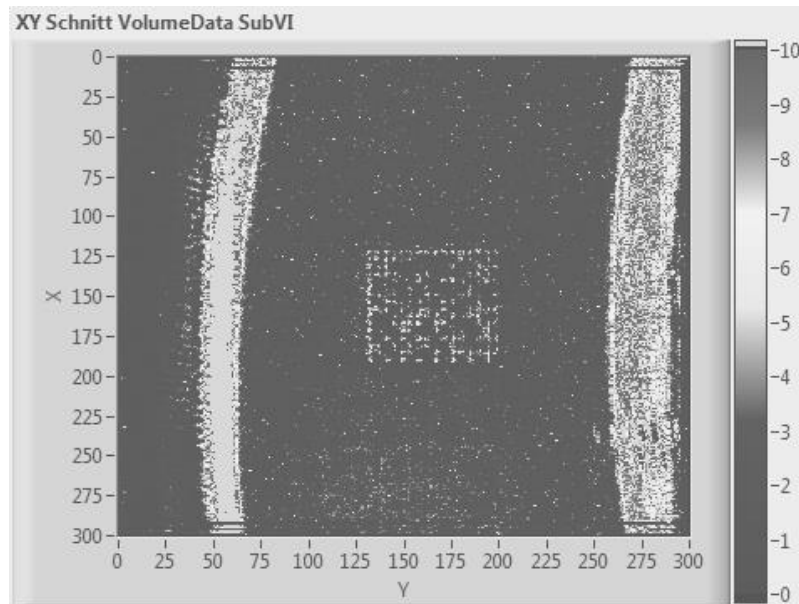

- Syringe-flange edge (red)
- Polarization (blue)

## Without polarizer

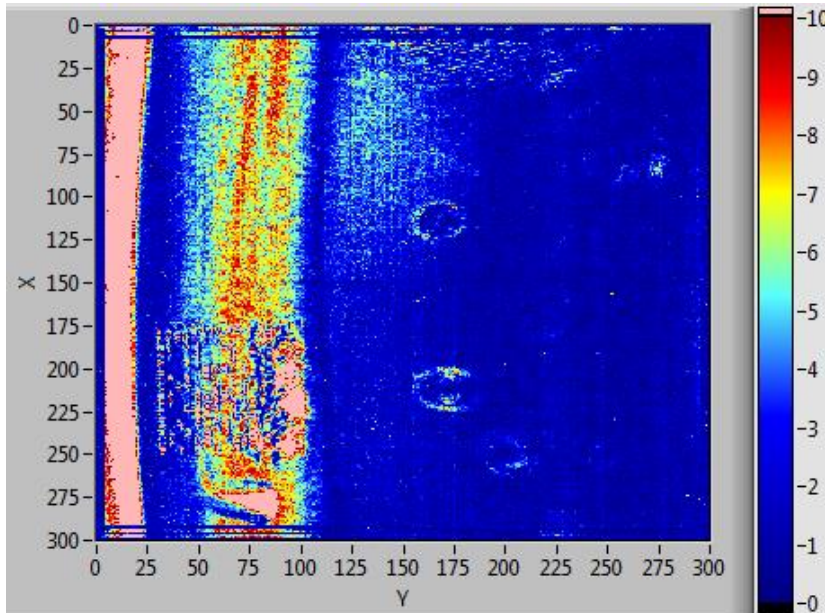

- Hidden code by polarization

## With polarizer

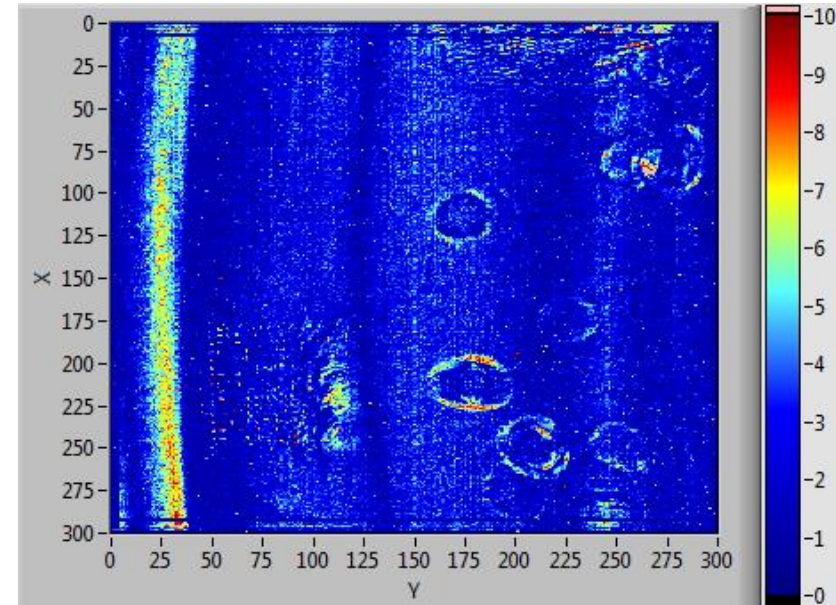

- Visible code

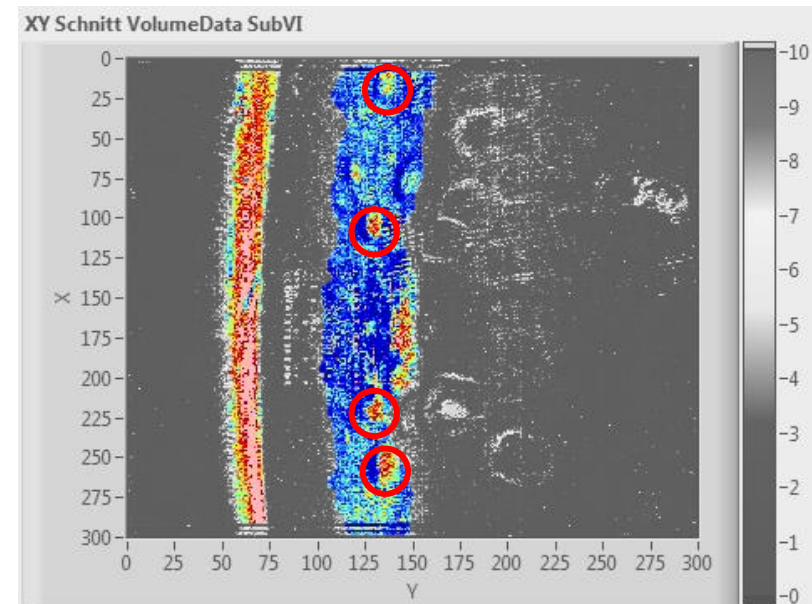
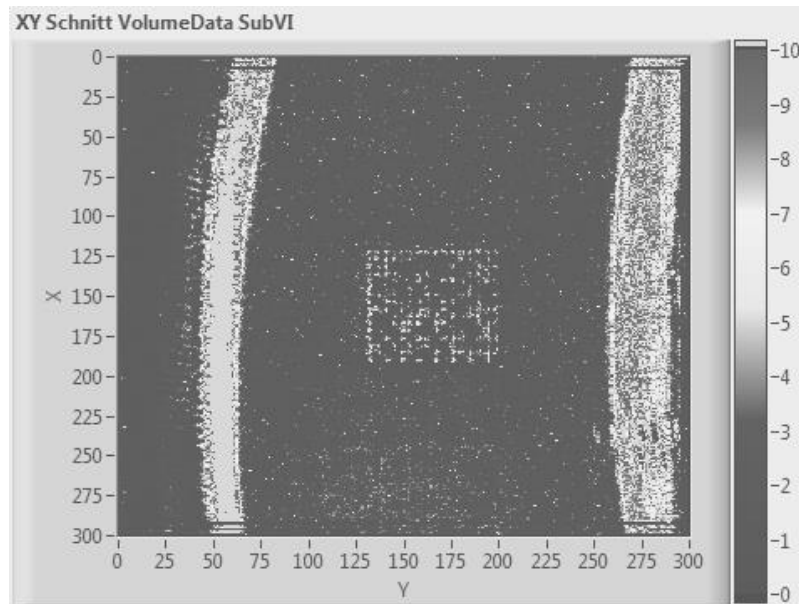

- Pores and cavities (red-rings)
- Impossible to read the code

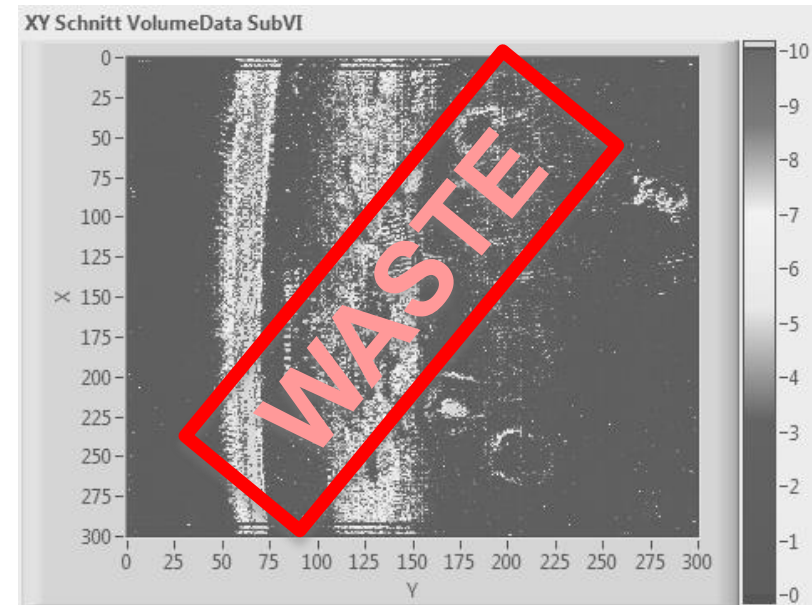
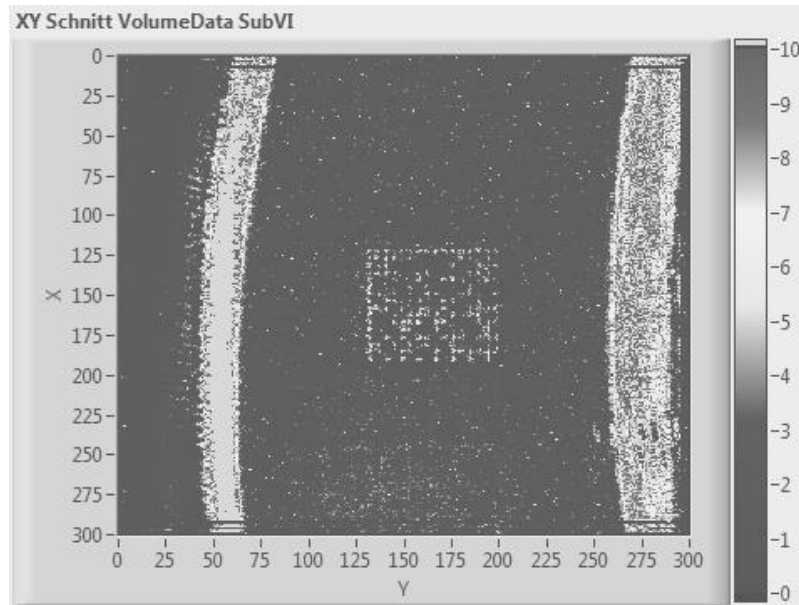

- Pores and cavities (red-rings)
- Impossible to read the code



## Surface types / syringe flanges

### Plane

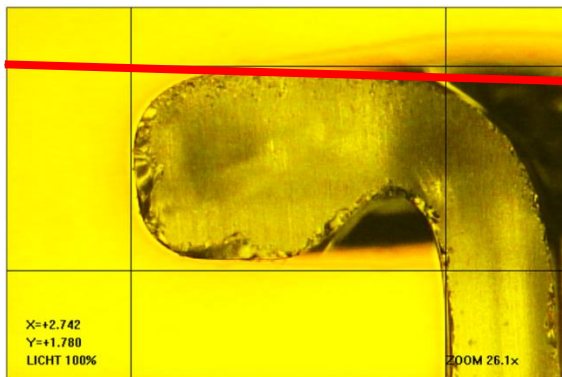

- Best conditions
- Wide range

### Angle

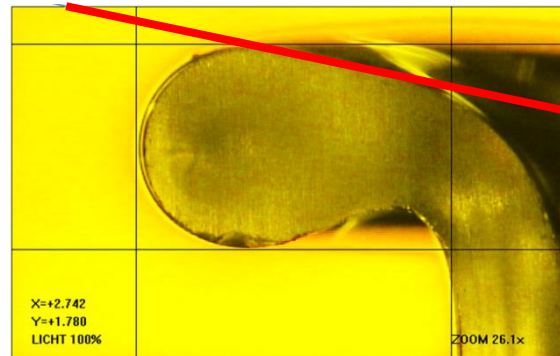

- Suitable conditions
- Limited range

### Undefined

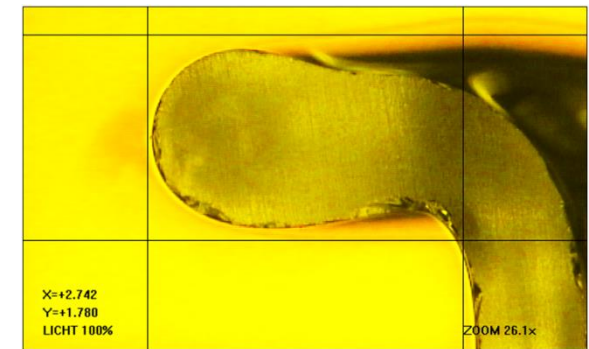

- Difficult conditions
- Undefined range

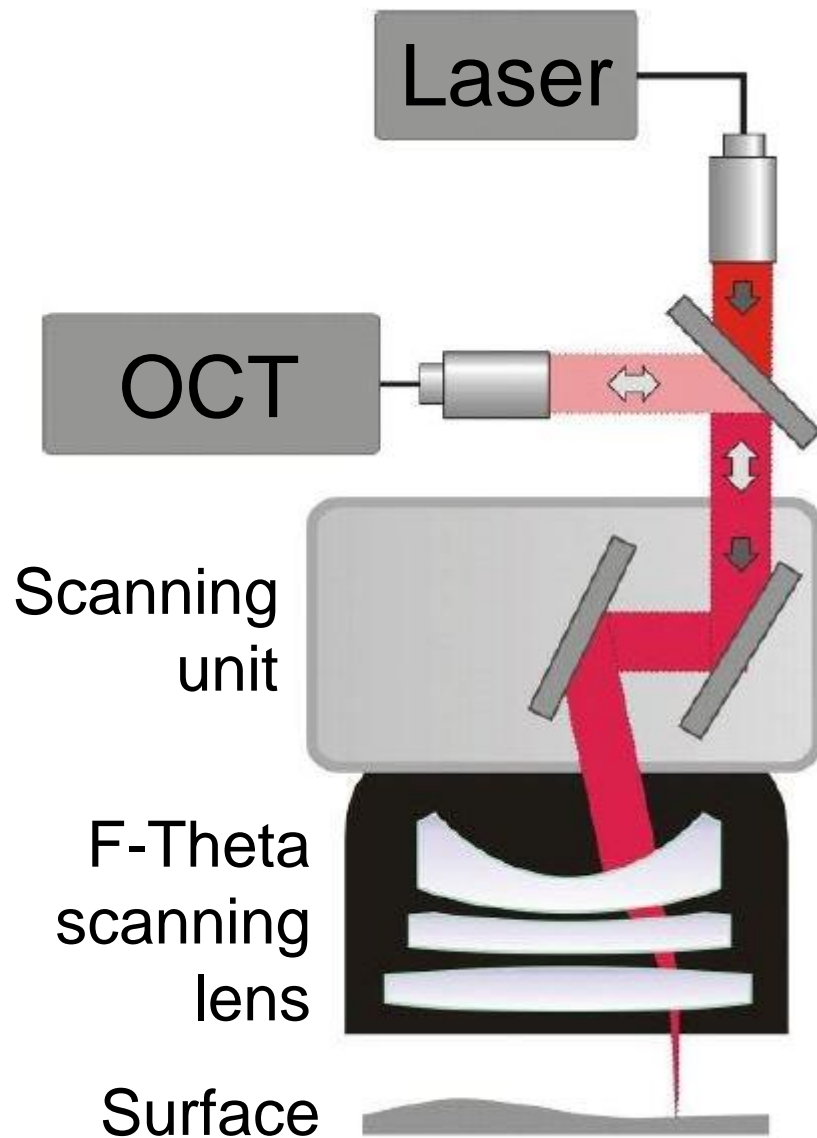

- Automatic process initialization (before)
- Adaptive machining (during)
- Inline control (during)
- Quality management (after)

source: WZL/Fraunhofer IPT

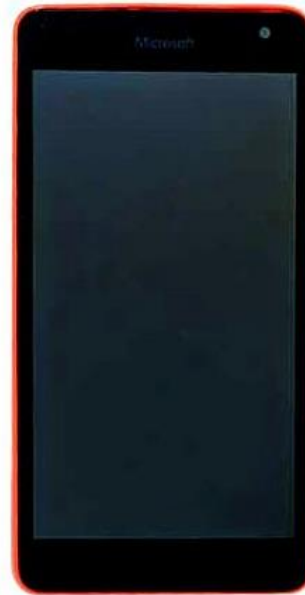

- Colored codes in transparent materials
- Functional structures
- Rotating polarizer to prevent polarization
- Improve the process of laser structuring in transparent materials

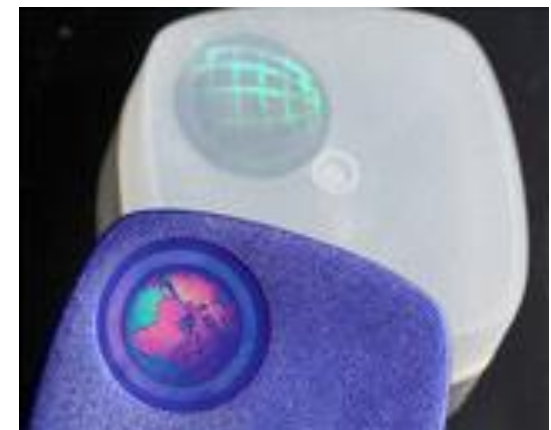

**Thank you for your attention**

# Contact information

University of Applied Sciences and Arts  
Northwestern Switzerland

Institute of Product and Production Engineering  
Klosterzelgstrasse 2  
CH-5210 Windisch

T +41 56 202 77 00

F +41 56 202 75 72

[info.ippe.technik@fhnw.ch](mailto:info.ippe.technik@fhnw.ch)

